

Axial fans made of plastic

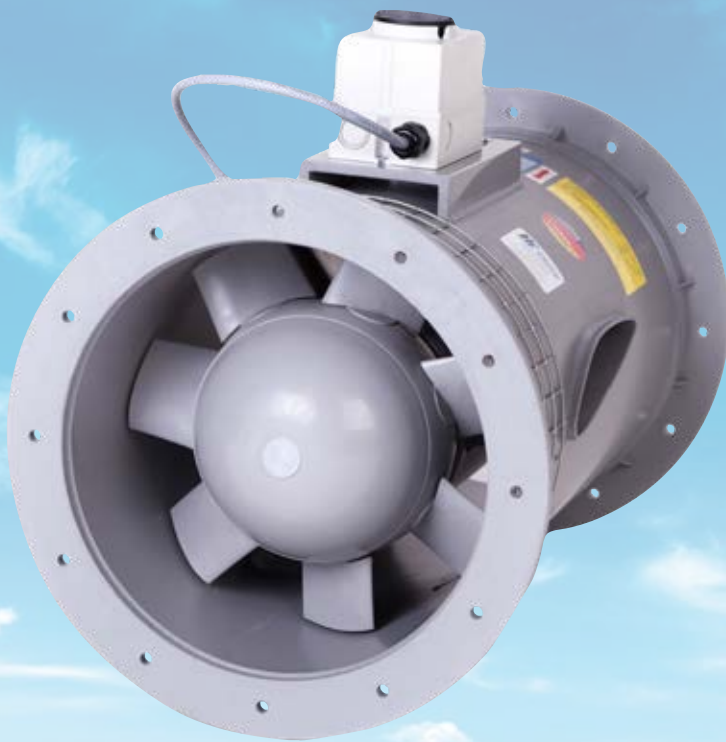

corrosion-resistant
compact design
for vertical and horizontal
installation

Why HLU?

90 years of experience in the plastic processing market

More than 10.000 m² production in Germany

Worldwide partner network

Large performance spectrum in air technology

Over 200 qualified employees

www.hlu.eu





Index

Axial fans made of plastic

Advantages, Design, Application	3
Specification	7
Dimension drawing	8
Characteristic curve and sound data	9
Accessories	24
Repair switch	28
Explosion protection ATEX	29

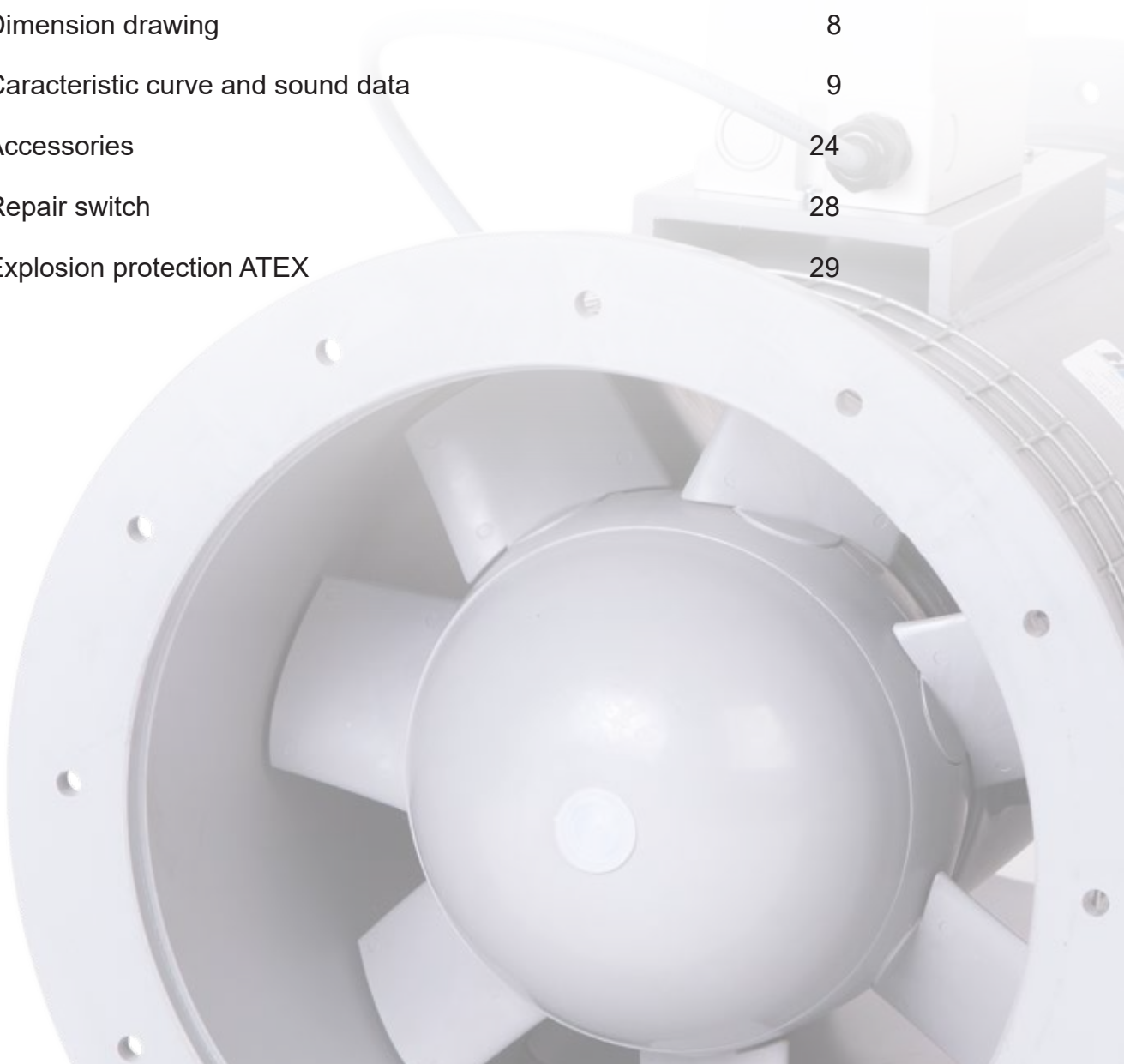

HF - Axial fan Type series HF A

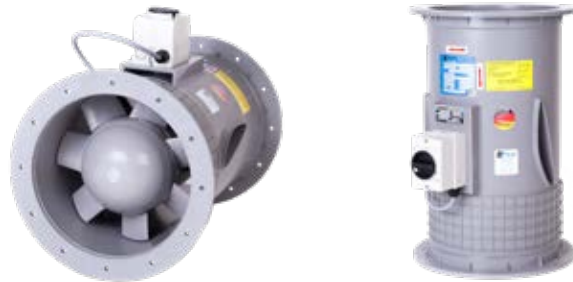

Advantages

- Corrosion-resistant
- Compact design
- Can be installed in horizontal and vertical position

Application

- Handling of exhaust air and corrosive gases
- Handling of explosive atmospheres from Ex zone 2
- Bottle- and box-cleaning systems in the beverage industry
- Water treatment plants
- Compact scrubber in the semiconductor industry
- Chemical and pharmaceutical industry

Design

- Internal motors separated from the air flow
- No metal parts in the air flow
- Impeller and Housing made of corrosion-resistant plastic
- Fitted as standard with repair switch or explosion-proof terminal box

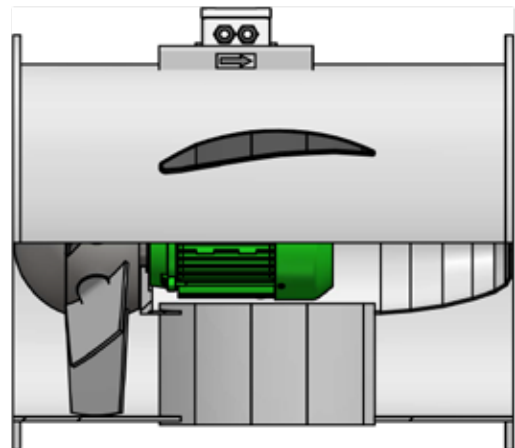

Accessories:



Sleeve
P. 24



Shaft seal
felt ring
P. 26



Protection grid
P. 26



HF - Axial fan
Type series HF A

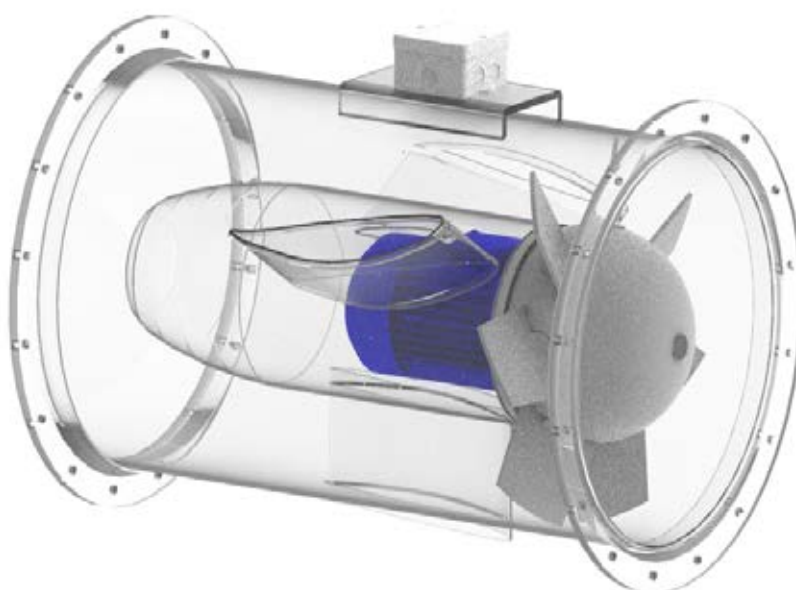

HLU's axial fans are the perfect solution where there is limited installation space and ideal for applications with large air volumes at low pressures. They offer compact installation dimensions with high volume flow, and the suction and discharge openings can be built into the

pipng system in any position. The internal motor is separated from the exhaust air flow to protect it from contaminated media.

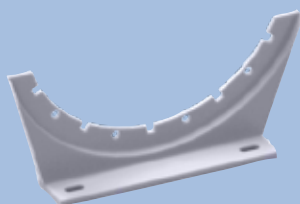

Mounting feet
P. 27



Wall bracket
P. 27



Repair switch
P. 28



Fans optionally available
for Ex-Zone!
P. 29

Why plastic?

- Durable
- Corrosion-resistant
- Resistant to chemicals
- High ductility
- Wide spectrum of materials

www.hlu.eu

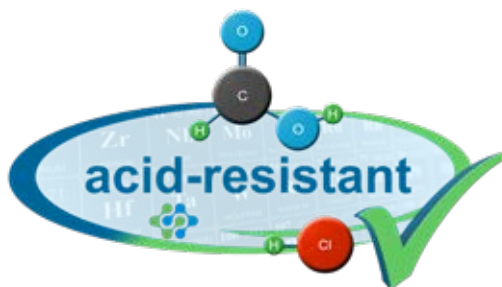



HF - Axial fan
Type series HF A

Specification

HF - Axial fan

Corrosion resistant plastic axial fan with housing in thermoplastic, in stable, welded version, flanged on both sides, splinter protection according to accident prevention rules, for installation in horizontal or vertical position. Impeller in PPs in injection-moulded version, float-mount on the motor shaft, statically and dynamically balanced, quality of balancing at least G 6.3 (DIN ISO 21940-11). The vane angle is adjustable in standstill by the factory. Including internally mounted motor, encapsulated against the delivery medium, and outside mounted repair switch in case of standard motors (without ex-protection) respectively externally mounted terminal box for ex-motors. The necessary external ventilation for the motor is outwards through hollow profiles.

Manufacturer	: HLU	
Type	: HF A ... - .. D	
Housing-material	: PPs	
Impeller-material	: PPs	
Inlet diameter	: ...	mm
Medium	: exhaust air	
Volume flow	: ...	m ³ /h
Total pressure difference	: ...	Pa
Static pressure difference	: ...	Pa
Sound pressure level Lp2A (1 m)	: ...	dB(A)
SFP	: ...	W/(m ³ /s)
Motor power	: ...	kW
Voltage	: ...	V
Frequency	: ...	Hz
Rated current	: ...	A
Enclosure/motor protection	: IP 55 / PTC	

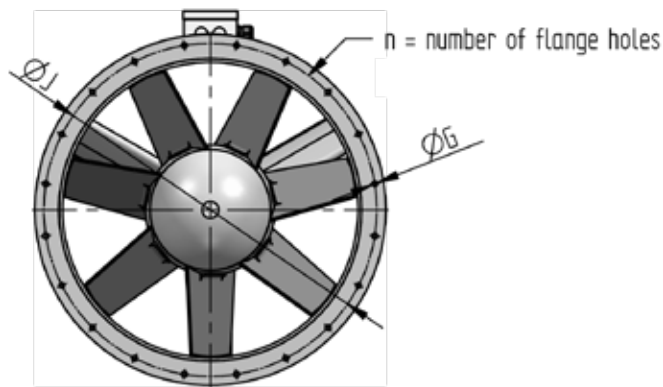
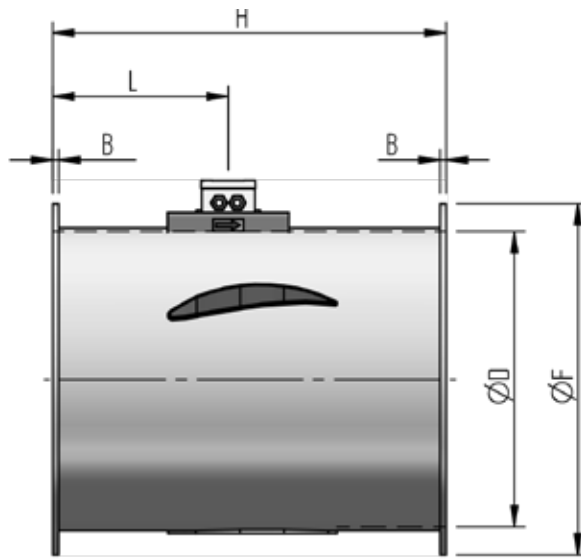

Size - Type	Dimensions [mm]								kg
	Outer diameter Ø	B	ØD	ØF	ØG	H	ØJ	L	
200-.. D	8	192	270	7	460	240	230	8	15
250-.. D	8	244	320	7	500	290	240	12	18
315-.. D	10	309	395	9	600	350	265	12	25
400-.. D	10	390	480	9	660	445	285	16	35
500-.. D	10	487	580	9	650	550	290	20	40
630-.. D	15	630	722	11	830	690	340	24	70
800-.. D	15	800	920	11	1050	880	310	30	130
1000-.. D	15	1000	1140	14	1400	1090	420	36	300

Dimensions and design are subject to change

Accessories:

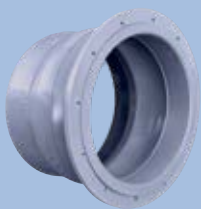

Sleeve
P. 24



Shaft seal
felt ring
P. 26



Protection grid
P. 26

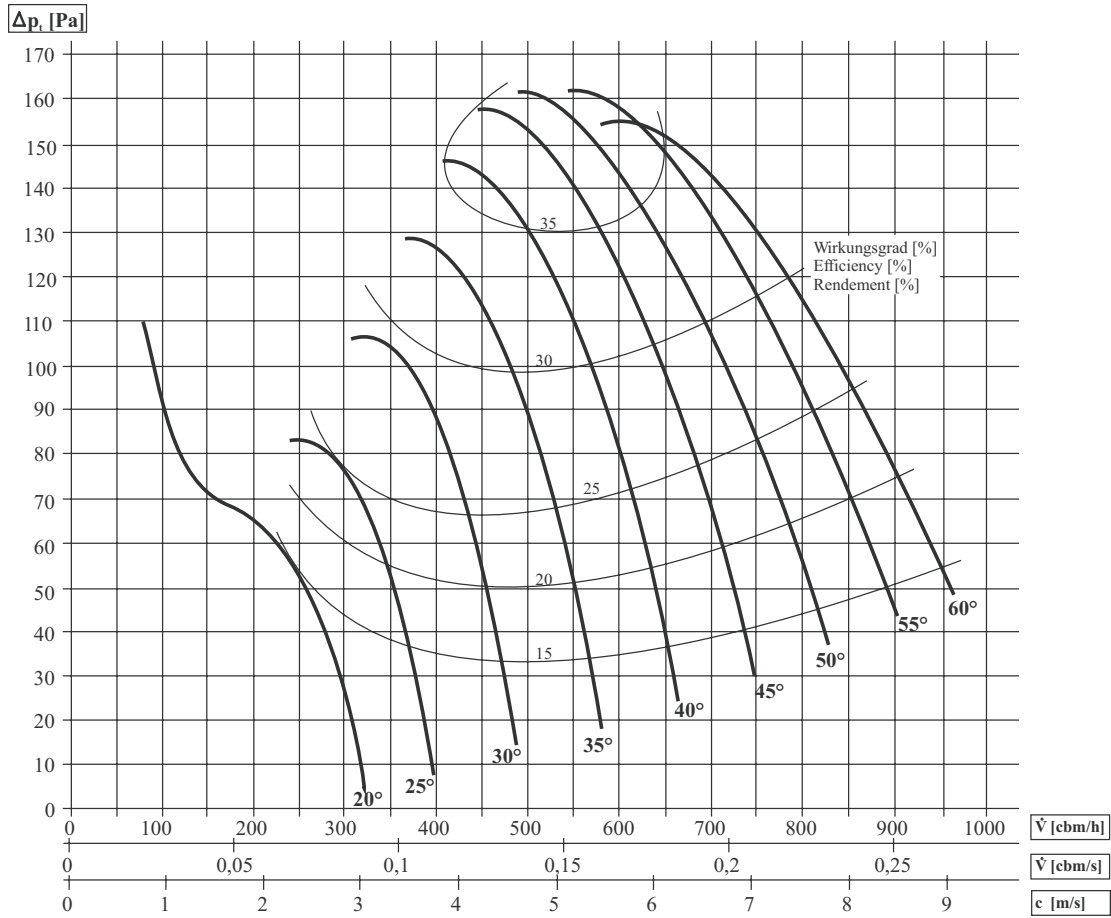

Acoustic level according to DIN 45635									
Vane angle	Free inlet / free outlet sound level A-weighted Lw5A = Lw6A								Measurement area sound pressure level Lp2A with connected pipes 1 m distance [dB(A)]
	Averaged octave bands [Hz]								
	63	125	250	500	1000	2000	4000	8000	
60°	57	59	65	71	66	61	55	45	60
55°	56	58	64	69	65	61	56	46	59
50°	54	56	63	67	63	61	57	46	58
45°	53	55	62	66	62	61	57	46	57
40°	53	54	61	64	60	61	58	47	56
35°	52	54	61	63	59	61	56	46	56
30°	52	54	62	63	58	60	56	47	56
25°	52	53	60	62	57	59	55	46	55
20°	52	52	59	61	55	57	57	44	54

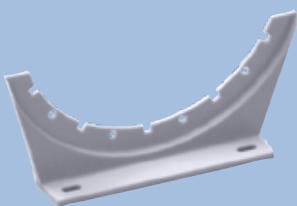

Mounting feet
P. 27



Wall bracket
P. 27



Repair switch
P. 28



Fans optionally available
for Ex-Zone!
P. 29

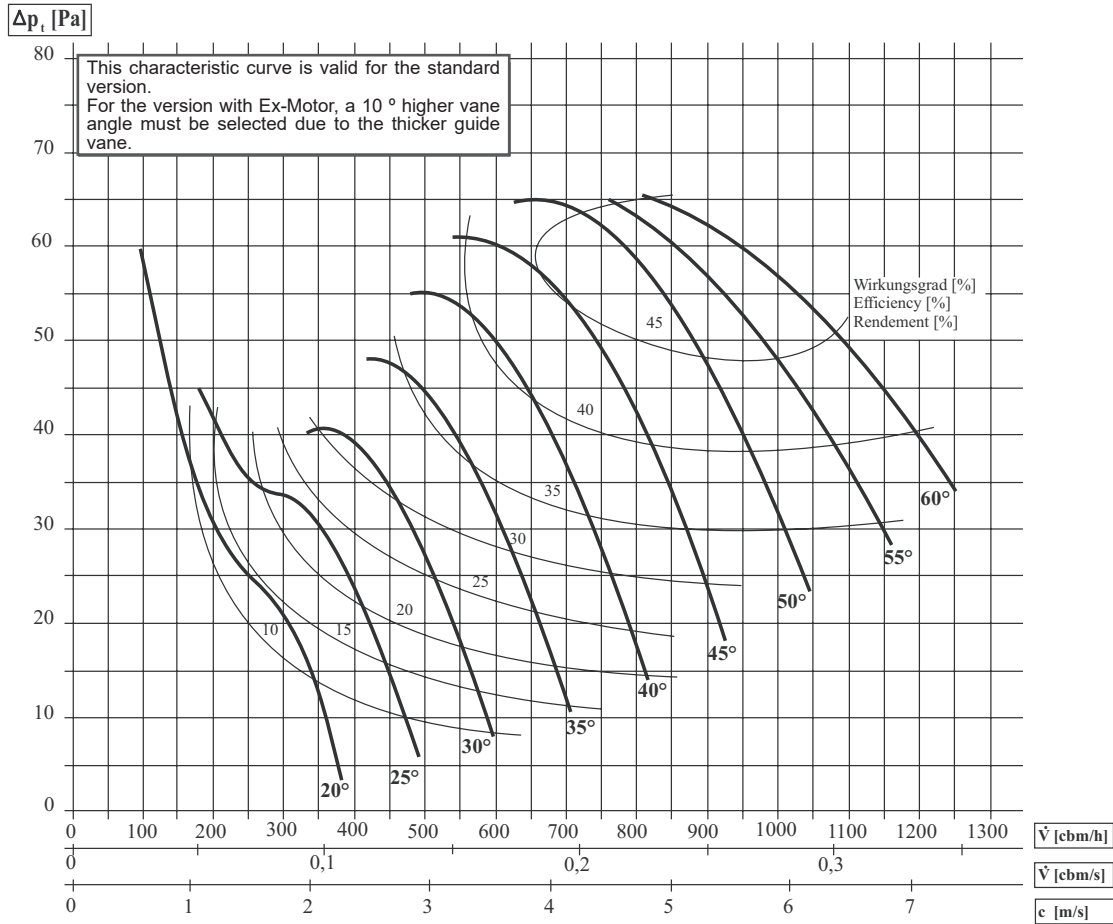

Acoustic level according to DIN 45635									
Vane angle	Free inlet / free outlet sound level A-weighted Lw5A = Lw6A								Measurement area sound pressure level Lp2A with connected pipes 1 m distance [dB(A)]
	Averaged octave bands [Hz]								
	63	125	250	500	1000	2000	4000	8000	
60°	50	56	57	58	56	54	50	32	53
55°	49	57	56	55	56	54	50	32	52
50°	47	54	54	53	55	55	49	31	51
45°	47	53	54	53	55	54	48	30	50
40°	43	50	50	51	54	53	21	17	48
35°	46	53	53	50	52	51	20	16	49
30°	43	53	54	51	53	49	21	19	48
25°	43	54	57	56	56	49	22	20	49
20°	44	55	50	54	53	50	25	21	50

Accessories:

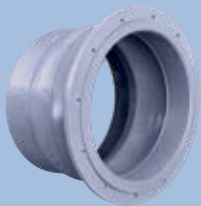

Sleeve
P. 24



Shaft seal
felt ring
P. 26



Protection grid
P. 26

HF A 250-..° D

n = 3000 1/min | P_M = 0,25 kW

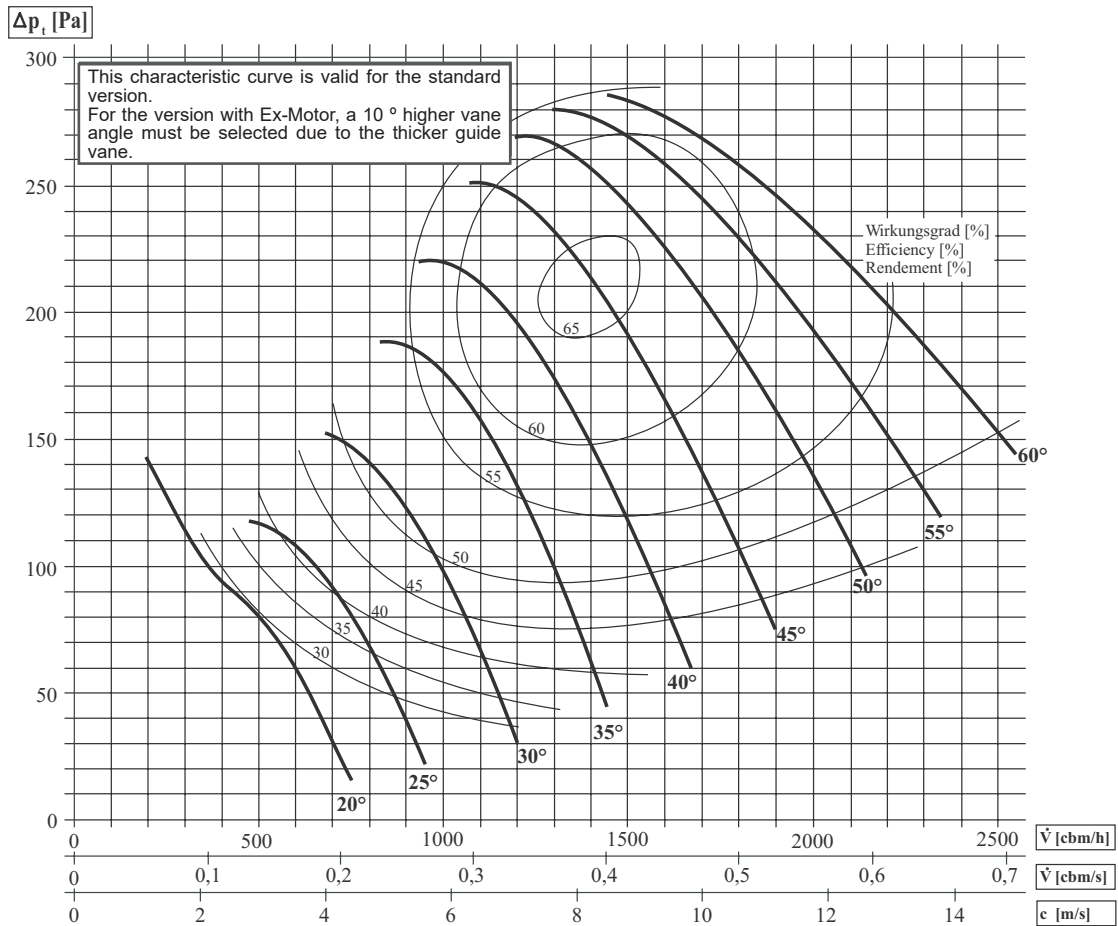

Acoustic level according to DIN 45635									
Vane angle	Free inlet / free outlet sound level A-weighted Lw5A = Lw6A								Measurement area sound pressure level Lp2A with connected pipes 1 m distance [dB(A)]
	Averaged octave bands [Hz]								
	63	125	250	500	1000	2000	4000	8000	
60°	57	65	74	73	73	67	65	56	67
55°	57	62	72	71	70	66	66	55	66
50°	58	63	71	69	69	66	65	54	65
45°	59	61	69	70	70	65	63	54	64
40°	59	60	67	67	69	66	64	53	62
35°	59	60	67	67	69	64	61	52	63
30°	60	59	65	64	67	65	63	52	61
25°	61	58	64	65	68	64	60	50	60
20°	62	57	62	62	65	65	61	48	58

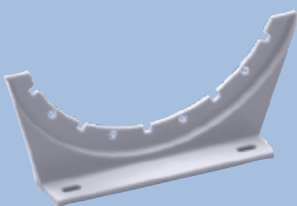

Mounting feet
P. 27



Wall bracket
P. 27



Repair switch
P. 28



Fans optionally available
for Ex-Zone!
P. 29

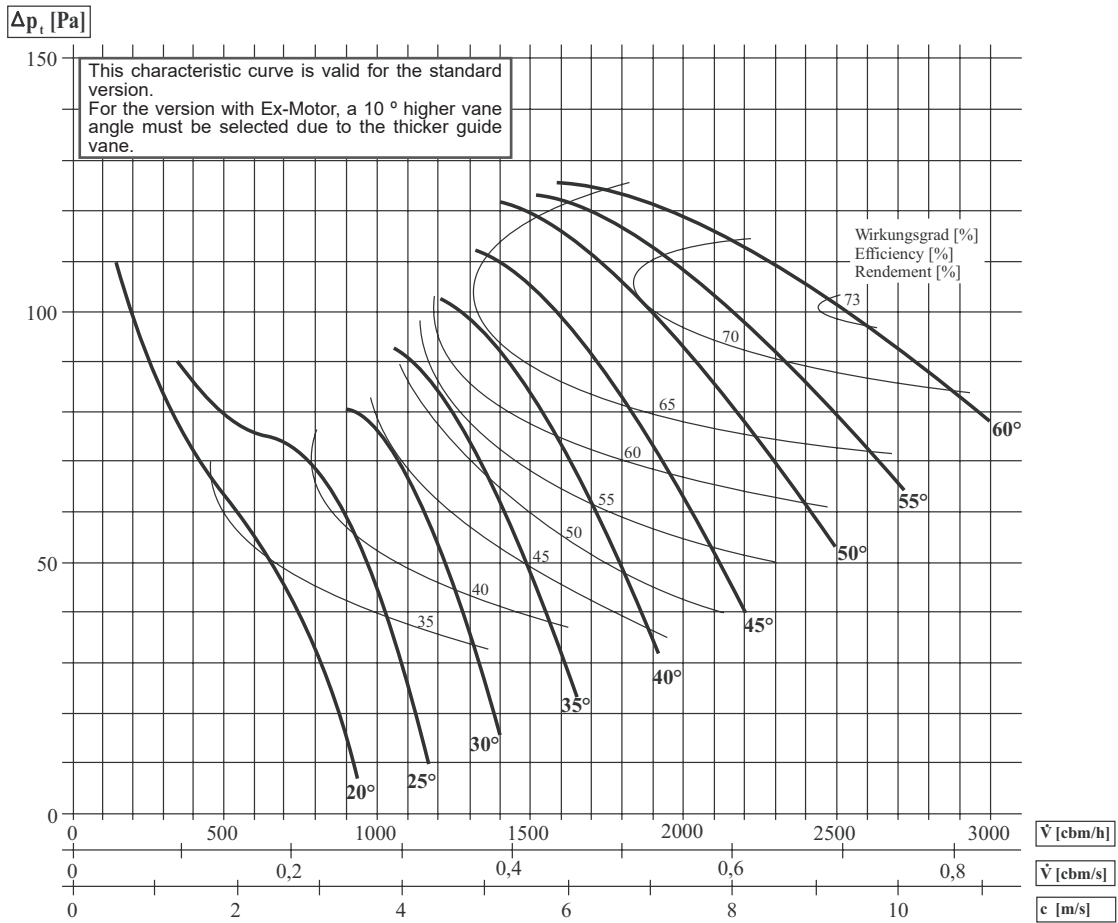

Acoustic level according to DIN 45635									
Vane angle	Free inlet / free outlet sound level A-weighted $L_{w5A} = L_{w6A}$								Measurement area sound pressure level L_{p2A} with connected pipes 1 m distance [dB(A)]
	Averaged octave bands [Hz]								
	63	125	250	500	1000	2000	4000	8000	
60°	52	60	63	65	63	63	59	48	60
55°	52	61	62	62	61	61	58	48	59
50°	52	64	60	60	60	60	57	45	59
45°	51	58	56	58	59	59	57	45	56
40°	50	55	54	55	58	59	56	24	54
35°	50	53	53	55	58	59	55	22	53
30°	49	52	52	54	57	56	52	23	52
25°	47	53	58	64	62	58	51	25	54
20°	49	55	59	65	64	58	50	28	59

Accessories:

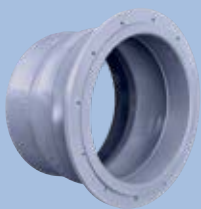

Sleeve
P. 24



Shaft seal
felt ring
P. 26



Protection grid
P. 26

HF A 315-..° D

n = 3000 1/min | P_M = 0,55 kW

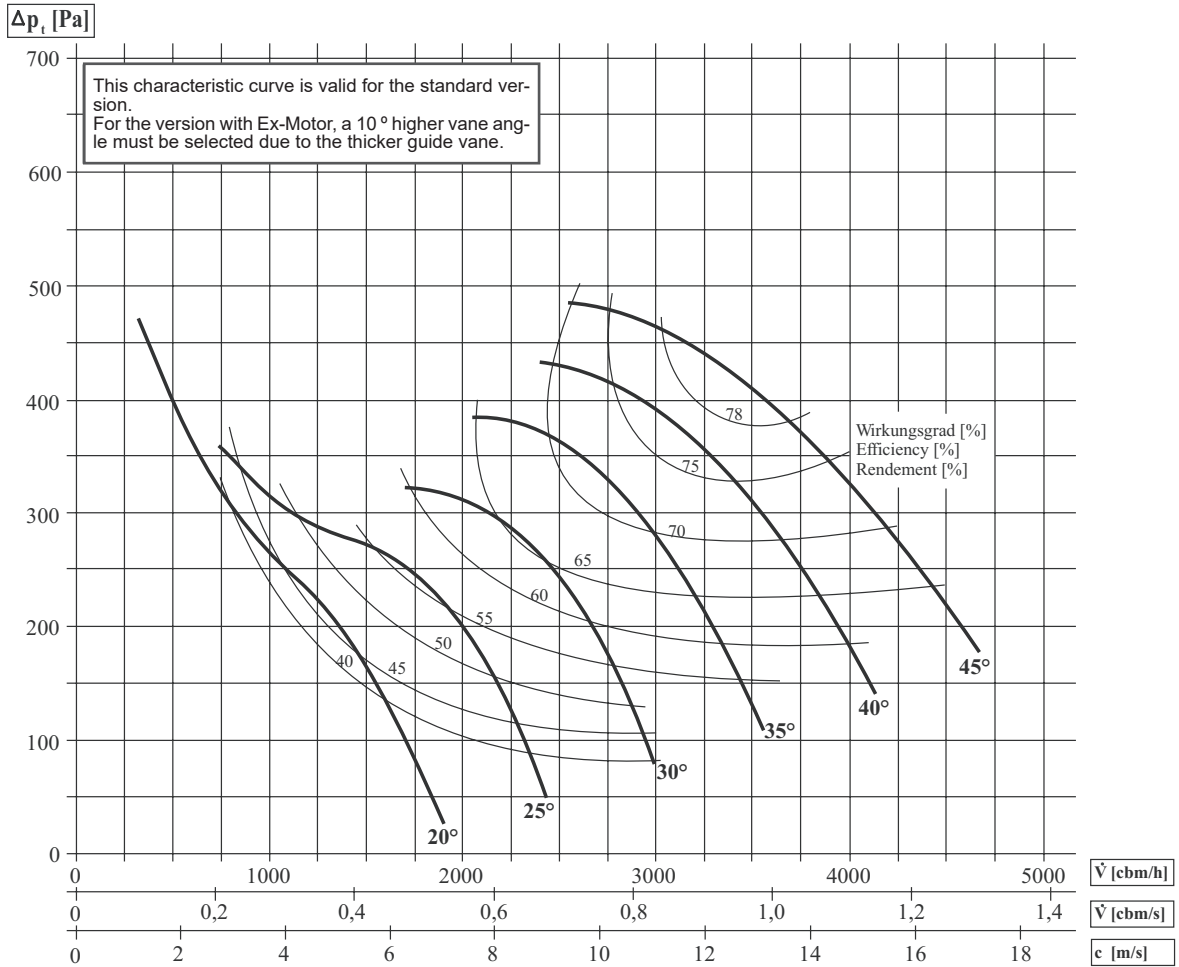

Acoustic level according to DIN 45635									
Vane angle	Free inlet / free outlet sound level A-weighted Lw5A = Lw6A								Measurement area sound pressure level Lp2A with connected pipes 1 m distance [dB(A)]
	Averaged octave bands [Hz]								
	63	125	250	500	1000	2000	4000	8000	
45°	65	67	74	75	75	72	71	67	71
40°	67	66	71	74	74	73	72	66	70
35°	69	65	70	73	73	71	70	60	69
30°	69	63	67	70	71	70	70	60	66
25°	72	59	68	69	72	71	70	59	65
20°	63	61	72	76	82	78	73	61	74

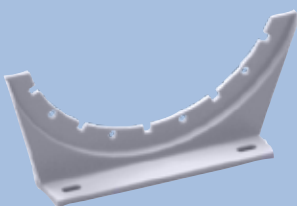

Mounting feet
P. 27



Wall bracket
P. 27



Repair switch
P. 28



Fans optionally available
for Ex-Zone!
P. 29

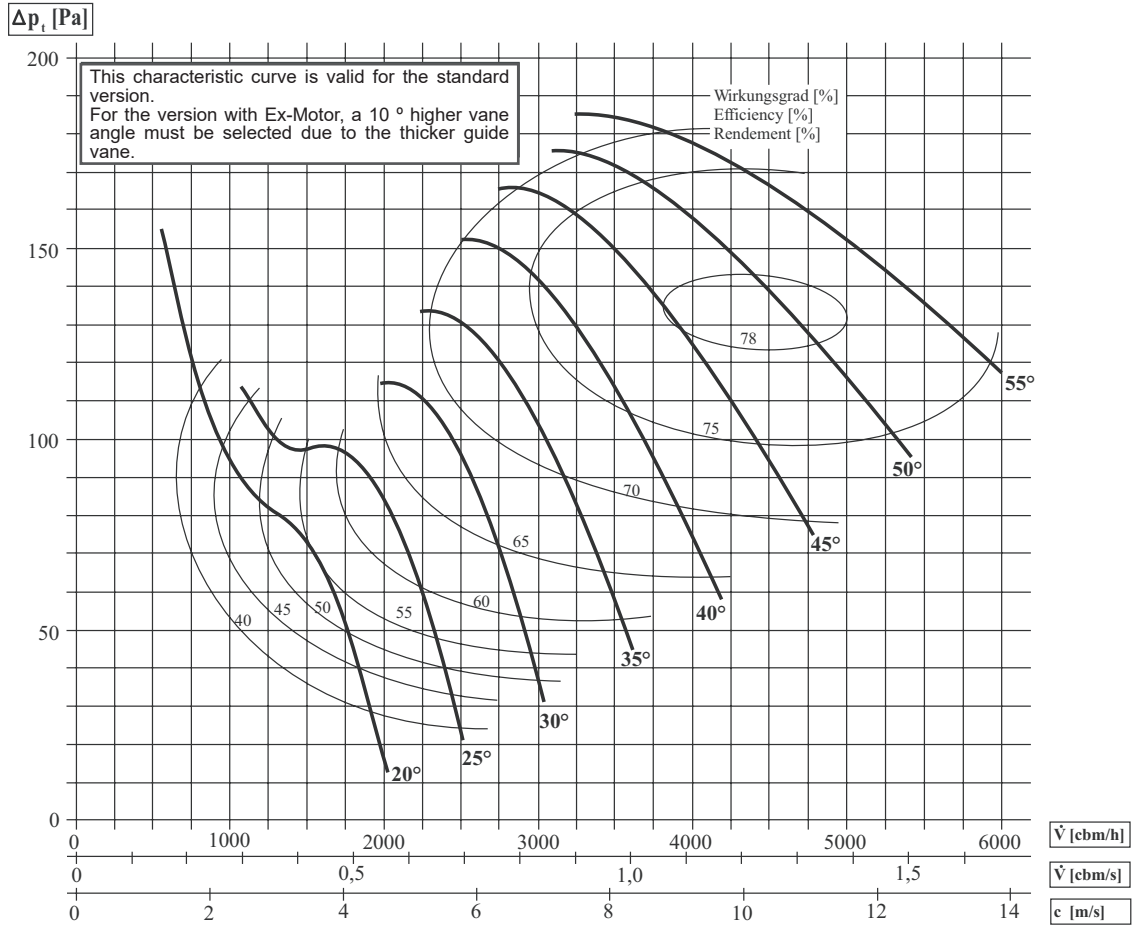

Acoustic level according to DIN 45635									
Vane angle	Free inlet / free outlet sound level A-weighted Lw5A = Lw6A								Measurement area sound pressure level Lp2A with connected pipes 1 m distance [dB(A)]
	Averaged octave bands [Hz]								
	63	125	250	500	1000	2000	4000	8000	
55°	53	61	61	68	71	67	65	56	65
50°	55	67	63	66	66	66	64	56	63
45°	54	62	63	63	64	64	62	53	61
40°	53	67	60	60	61	62	58	50	61
35°	51	57	58	57	60	61	57	49	57
30°	49	55	56	58	60	62	57	48	56
25°	47	55	57	60	63	62	56	47	58
20°	49	59	66	72	72	66	57	47	67

Accessories:

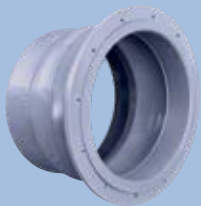

Sleeve
P. 24



Shaft seal
felt ring
P. 26



Protection grid
P. 26

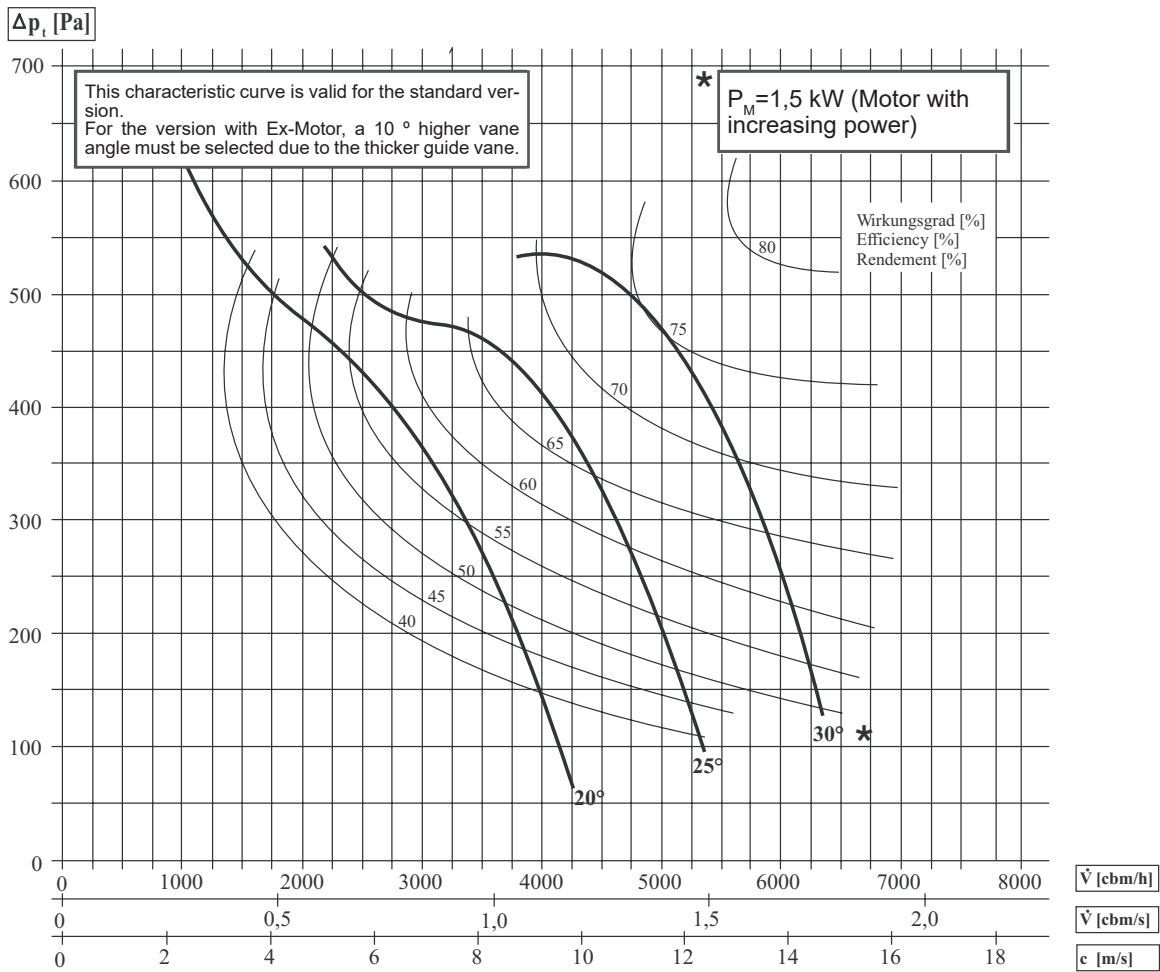

Acoustic level according to DIN 45635									
Vane angle	Free inlet / free outlet sound level A-weighted L _{w5A} = L _{w6A}								Measurement area sound pressure level L _{p2A} with connected pipes 1 m distance [dB(A)]
	Averaged octave bands [Hz]								
	63	125	250	500	1000	2000	4000	8000	
30°	65	71	75	78	78	77	75	68	74
25°	63	68	74	76	79	80	76	68	74
20°	62	67	73	77	84	82	78	70	72

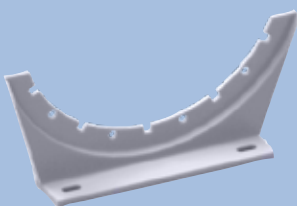

Mounting feet
P. 27



Wall bracket
P. 27



Repair switch
P. 28



Fans optionally available
for Ex-Zone!
P. 29

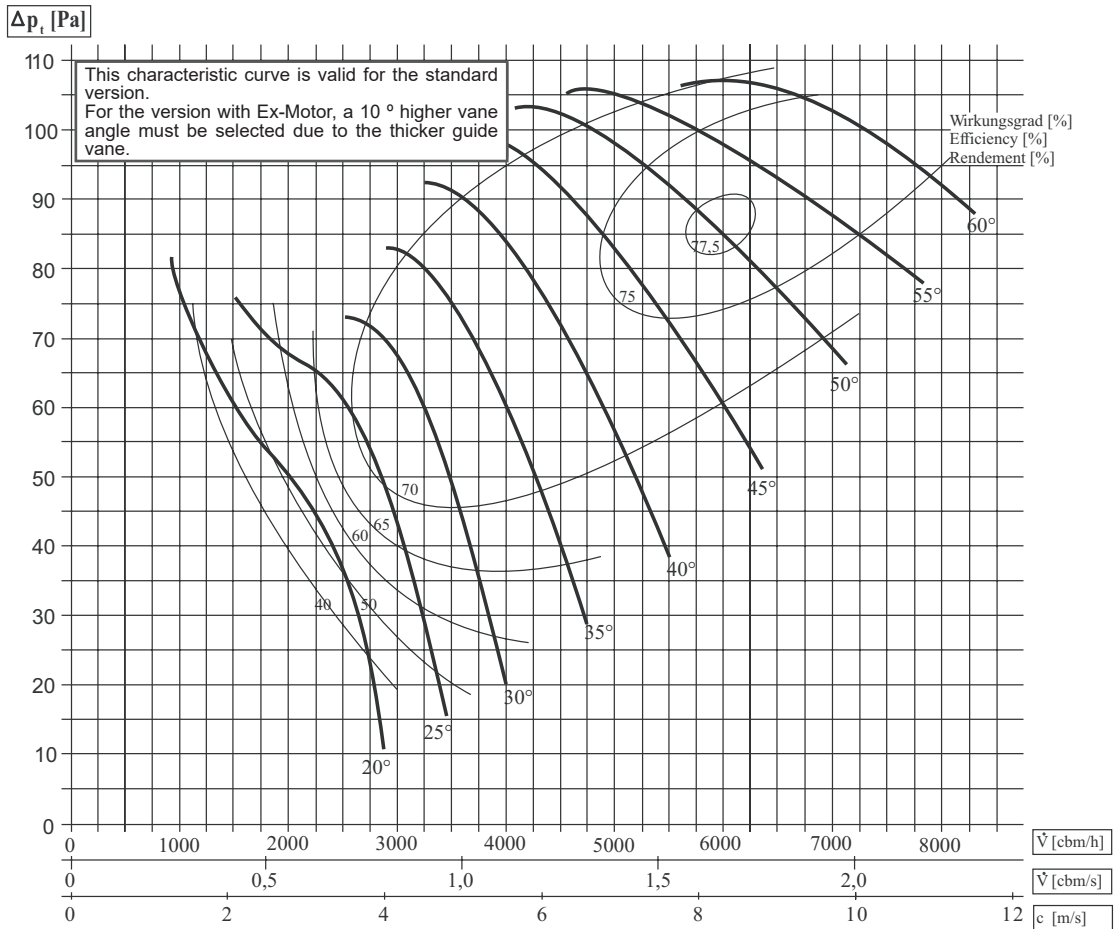

Acoustic level according to DIN 45635									
Vane angle	Free inlet / free outlet sound level A-weighted Lw5A = Lw6A								Measurement area sound pressure level Lp2A with connected pipes 1 m distance [dB(A)]
	Averaged octave bands [Hz]								
	63	125	250	500	1000	2000	4000	8000	
60°	53	61	63	63	63	63	58	49	60
55°	51	61	59	63	63	64	59	51	60
50°	51	58	59	62	62	63	59	51	59
45°	50	56	58	61	61	62	59	48	58
40°	48	55	58	59	61	62	58	46	57
35°	46	54	55	55	58	60	56	44	55
30°	45	53	55	54	57	59	53	44	54
25°	43	53	62	59	60	59	53	44	58
20°	39	51	62	65	64	60	52	11	60

Accessories:

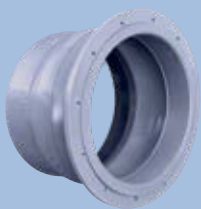

Sleeve
P. 24



Shaft seal
felt ring
P. 26



Protection grid
P. 26

HF A 500-..° D

n = 1500 1/min | P_M = 0,75 kW

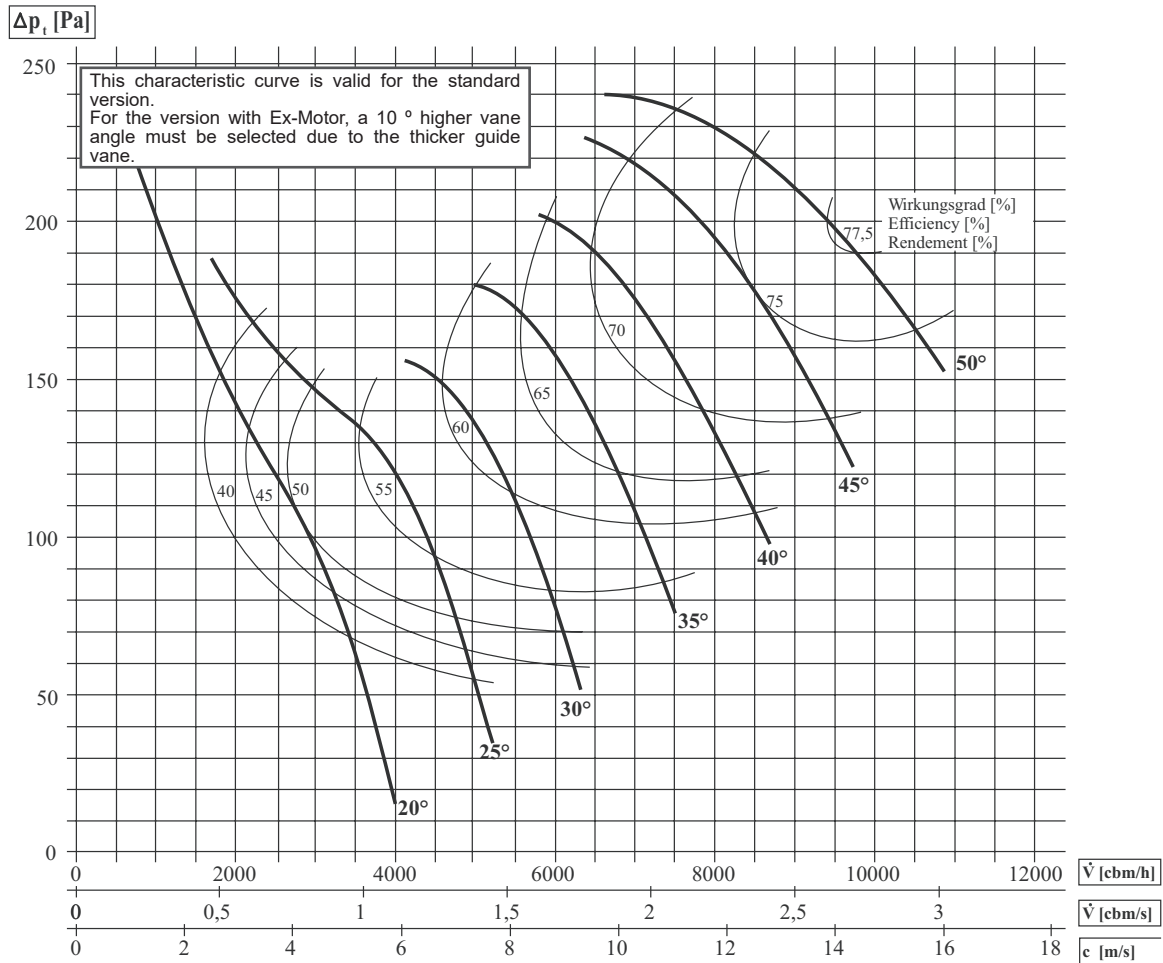

Acoustic level according to DIN 45635									
Vane angle	Free inlet / free outlet sound level A-weighted Lw5A = Lw6A								Measurement area sound pressure level Lp2A with connected pipes 1 m distance [dB(A)]
	Averaged octave bands [Hz]								
	63	125	250	500	1000	2000	4000	8000	
50°	61	75	71	73	73	72	71	63	71
45°	60	72	68	72	72	72	70	61	70
40°	58	68	66	71	71	71	69	59	68
35°	56	68	65	66	66	68	67	55	66
30°	54	69	65	65	66	68	66	54	66
25°	53	65	65	66	69	69	65	54	64
20°	50	64	68	76	77	74	67	55	72

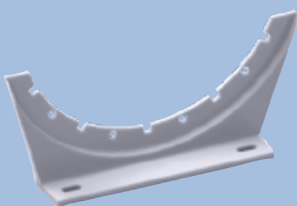

Mounting feet
P. 27



Wall bracket
P. 27



Repair switch
P. 28



Fans optionally available
for Ex-Zone!
P. 29

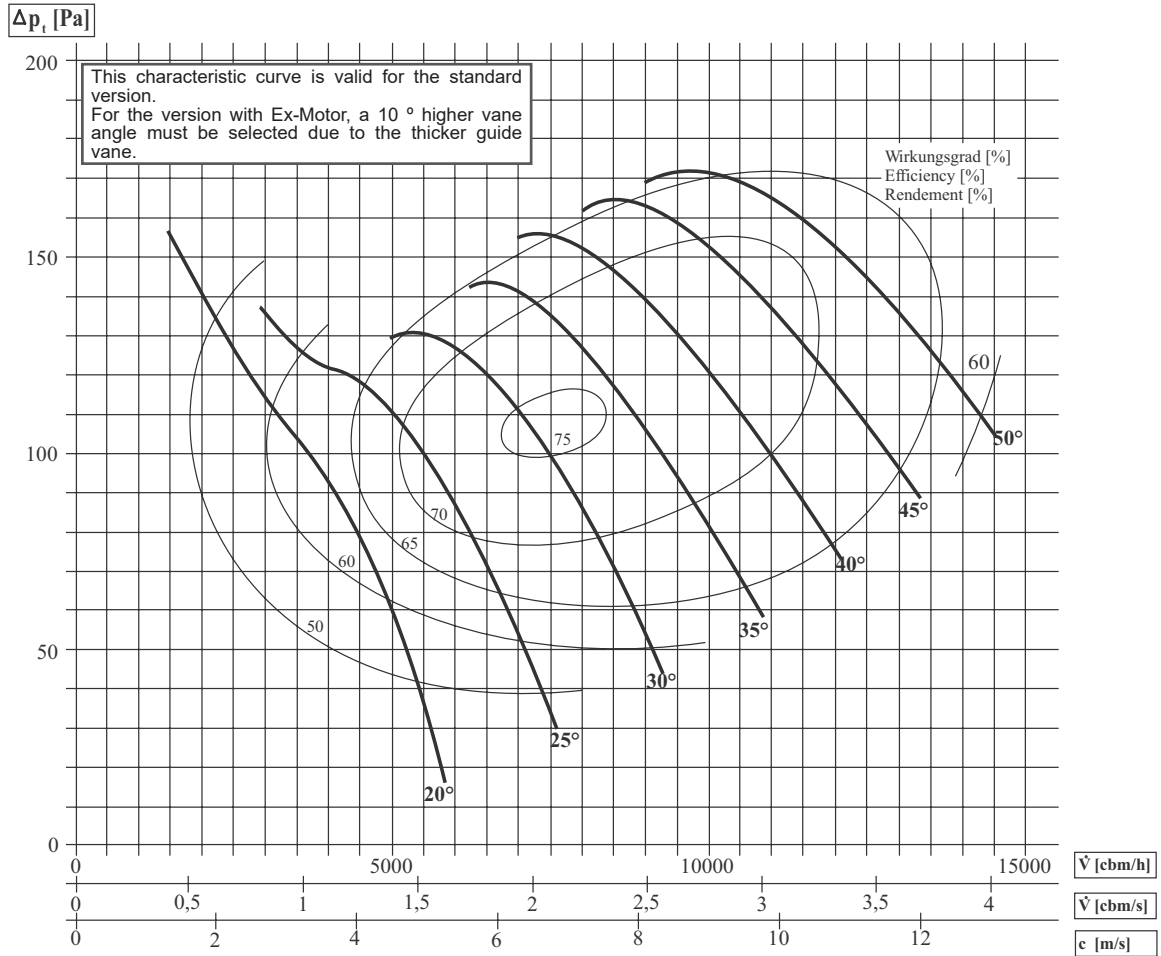

Acoustic level according to DIN 45635									
Vane angle	Free inlet / free outlet sound level A-weighted $L_{w5A} = L_{w6A}$								Measurement area sound pressure level L_{p2A} with connected pipes 1 m distance [dB(A)]
	Averaged octave bands [Hz]								
	63	125	250	500	1000	2000	4000	8000	
50°	62	66	70	72	71	70	65	54	68
45°	61	65	68	70	71	70	66	57	67
40°	62	64	68	69	70	70	65	55	66
35°	60	65	70	69	70	69	64	54	67
30°	58	66	72	71	70	69	62	51	68
25°	55	62	72	71	72	67	60	48	69
20°	54	67	69	73	71	64	55	45	70

Accessories:

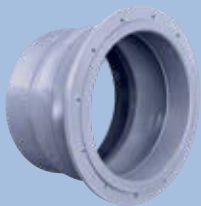

Sleeve
P. 24



Shaft seal
felt ring
P. 26



Protection grid
P. 26

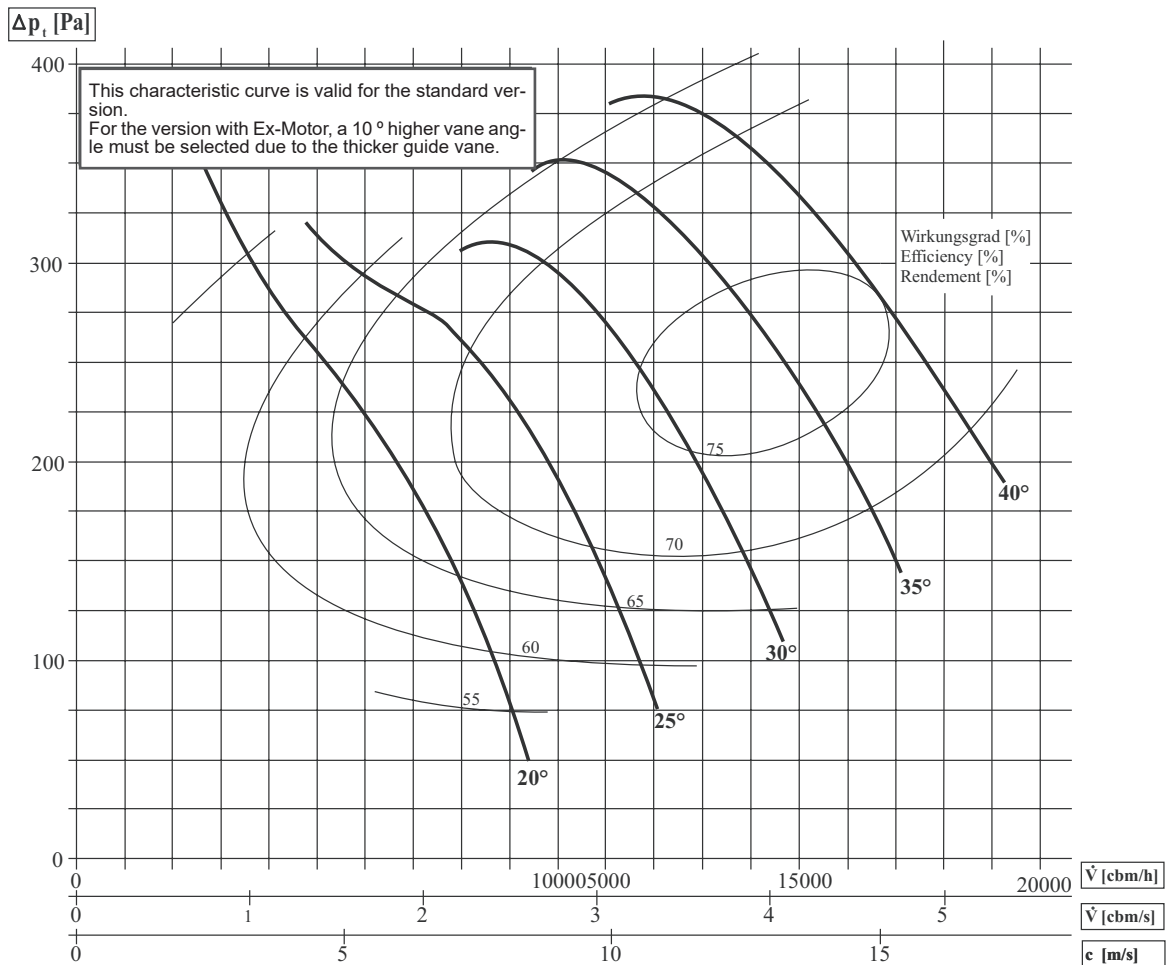

Acoustic level according to DIN 45635									
Vane angle	Free inlet / free outlet sound level A-weighted Lw5A = Lw6A								Measurement area sound pressure level Lp2A with connected pipes 1 m distance [dB(A)]
	Averaged octave bands [Hz]								
	63	125	250	500	1000	2000	4000	8000	
40°	69	75	75	80	78	76	73	66	76
35°	68	73	75	78	76	76	73	64	76
30°	66	74	75	78	77	76	72	62	75
25°	62	73	73	77	78	76	74	60	75
20°	61	75	80	86	87	83	73	60	82

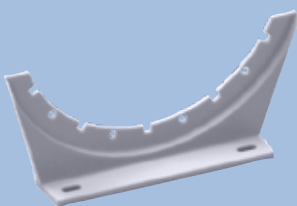

Mounting feet
P. 27



Wall bracket
P. 27



Repair switch
P. 28



Fans optionally available
for Ex-Zone!
P. 29

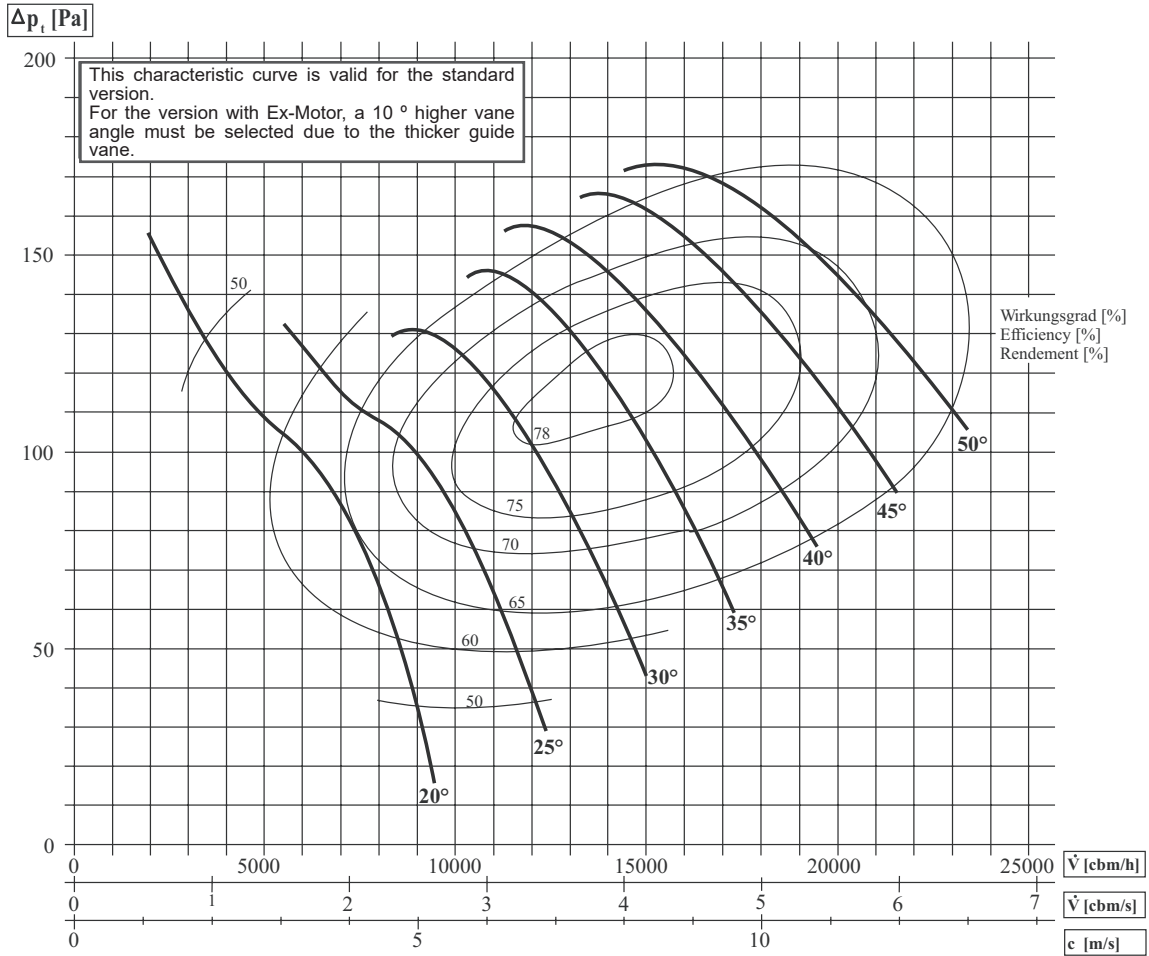

Acoustic level according to DIN 45635									
Vane angle	Free inlet / free outlet sound level A-weighted $L_{w5A} = L_{w6A}$								Measurement area sound pressure level L_{p2A} with connected pipes 1 m distance [dB(A)]
	Averaged octave bands [Hz]								
	63	125	250	500	1000	2000	4000	8000	
50°	60	67	70	71	72	70	64	54	70
45°	61	64	69	72	72	71	68	58	69
40°	61	63	70	71	72	72	67	57	68
35°	60	65	71	72	72	72	67	57	70
30°	59	65	72	73	72	71	63	53	70
25°	54	60	69	72	72	68	60	49	69
20°	51	59	69	74	73	68	59	48	70

Accessories:



Sleeve
P. 24



Shaft seal
felt ring
P. 26



Protection grid
P. 26

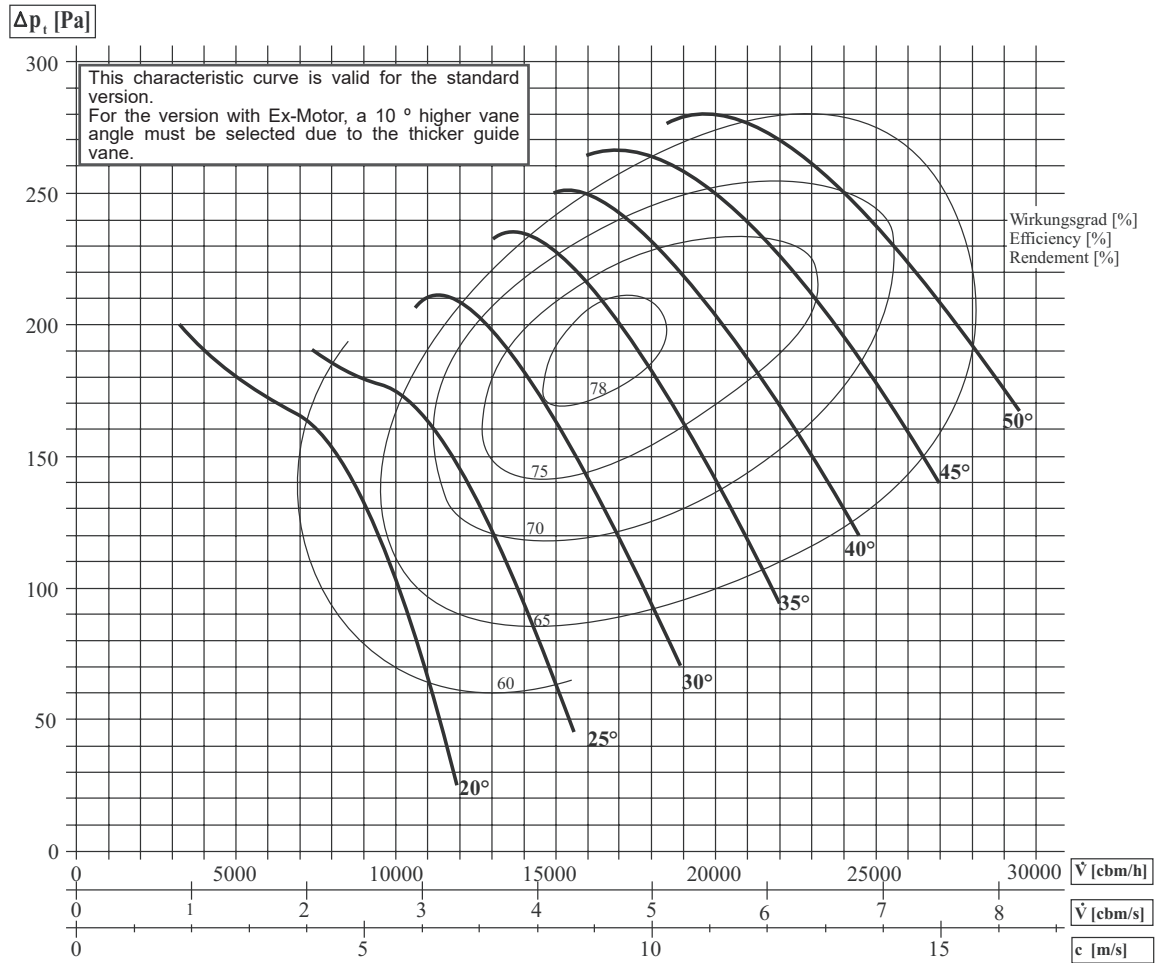

Acoustic level according to DIN 45635									
Vane angle	Free inlet / free outlet sound level A-weighted Lw5A = Lw6A								Measurement area sound pressure level Lp2A with connected pipes 1 m distance [dB(A)]
	Averaged octave bands [Hz]								
	63	125	250	500	1000	2000	4000	8000	
50°	66	70	75	80	79	79	75	67	76
45°	62	68	73	78	79	78	75	66	75
40°	67	70	75	79	78	76	73	66	75
35°	66	70	75	79	79	78	75	66	76
30°	64	70	77	81	81	80	76	66	78
25°	62	69	73	79	81	79	74	64	77
20°	53	63	69	77	79	75	65	52	74

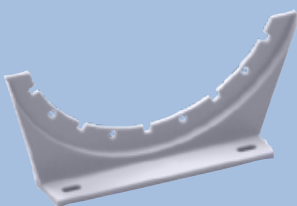

Mounting feet
P. 27



Wall bracket
P. 27



Repair switch
P. 28



Fans optionally available
for Ex-Zone!
P. 29

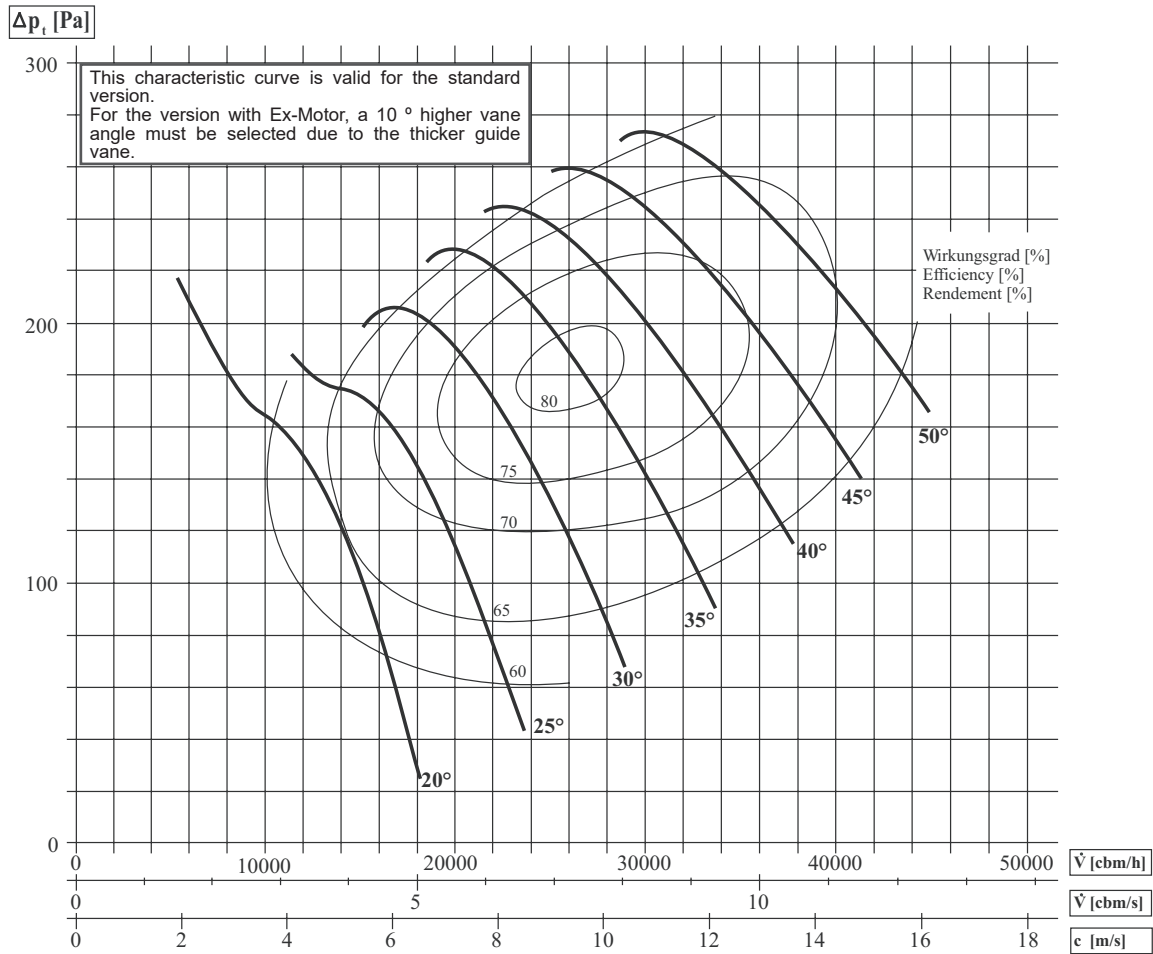

Acoustic level according to DIN 45635									
Vane angle	Free inlet / free outlet sound level A-weighted $L_{w5A} = L_{w6A}$								Measurement area sound pressure level L_{p2A} with connected pipes 1 m distance [dB(A)]
	Averaged octave bands [Hz]								
	63	125	250	500	1000	2000	4000	8000	
50°	65	69	75	81	80	79	76	66	75
45°	64	69	73	78	79	78	74	64	75
40°	65	68	74	77	78	78	73	63	74
35°	65	71	76	78	79	78	73	63	76
30°	64	71	78	80	80	78	71	60	77
25°	61	69	76	80	80	77	69	57	77
20°	55	64	73	79	79	74	64	53	74

Accessories:

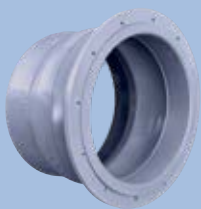

Sleeve
P. 24



Shaft seal
felt ring
P. 26



Protection grid
P. 26

HF A 1000-..° D

n = 1000 1/min | P_M = 11,0 kW

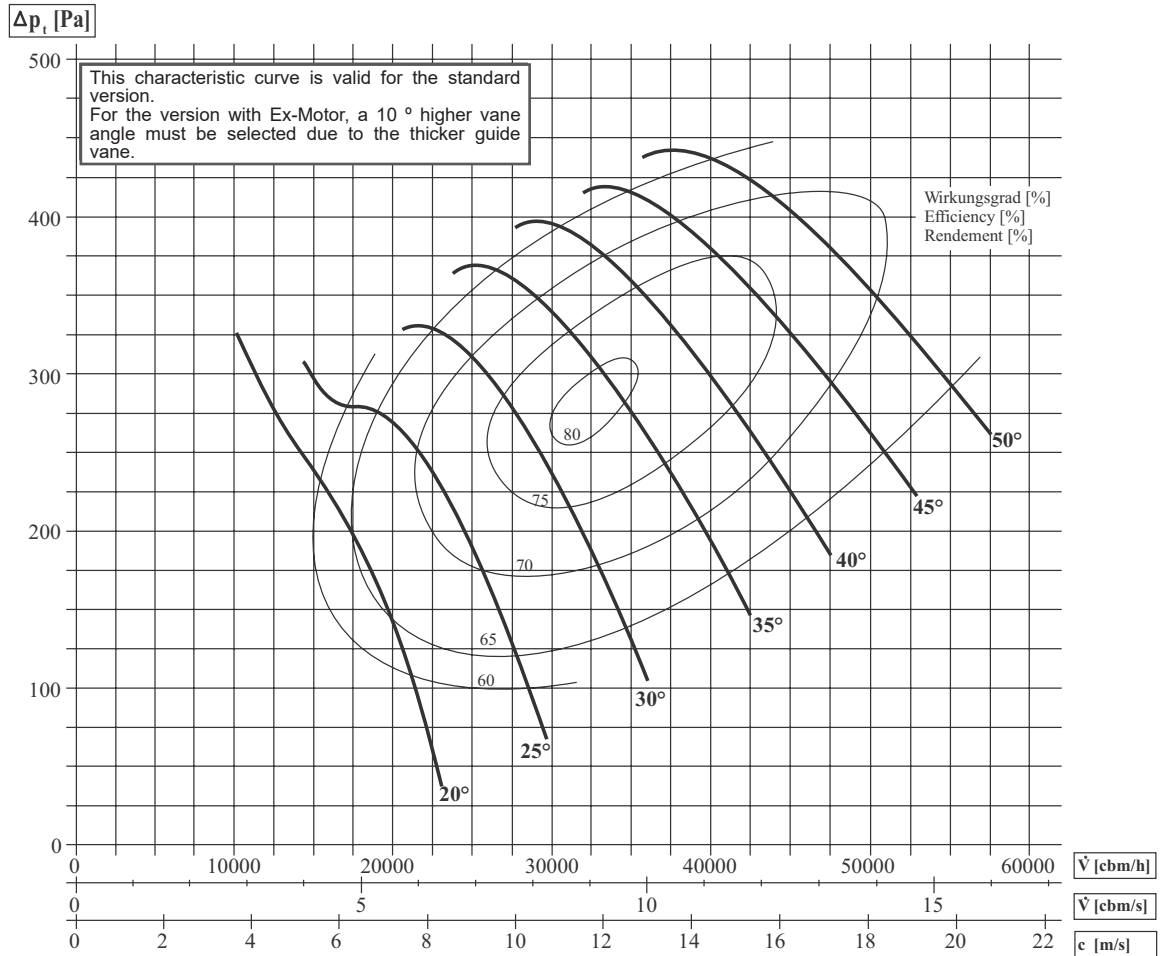

Acoustic level according to DIN 45635									
Vane angle	Free inlet / free outlet sound level A-weighted L _{w5A} = L _{w6A}								Measurement area sound pressure level L _{p2A} with connected pipes 1 m distance [dB(A)]
	Averaged octave bands [Hz]								
	63	125	250	500	1000	2000	4000	8000	
50°	68	74	80	87	87	86	83	75	83
45°	66	74	78	85	86	85	81	74	81
40°	69	73	79	84	83	81	78	71	79
35°	69	75	80	85	84	83	80	71	82
30°	70	78	83	86	86	84	80	71	82
25°	65	75	77	82	84	82	78	66	79
20°	57	69	75	82	85	80	70	57	79

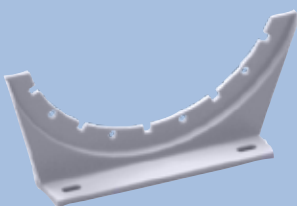

Mounting feet
P. 27



Wall bracket
P. 27



Repair switch
P. 28



Fans optionally available
for Ex-Zone!
P. 29

Accessories for
HF - Axial fans
Type series HF A



Sleeve with flange

For easy flexible connection to duct

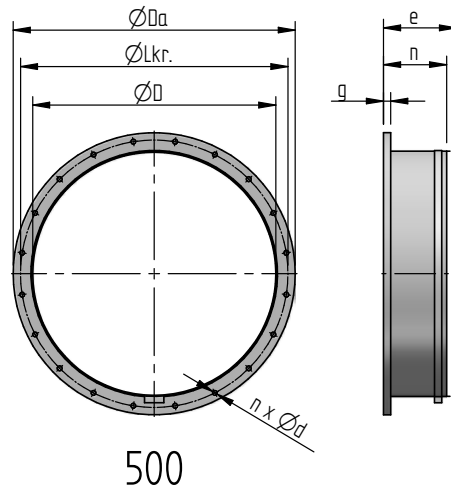
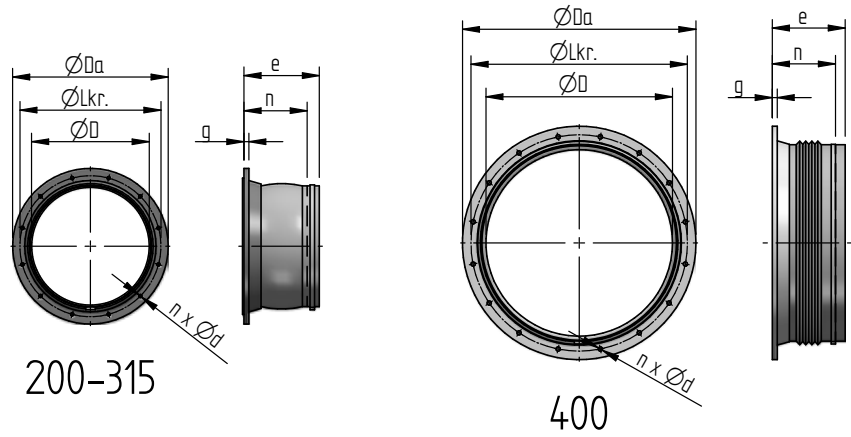

Size	Dimension [mm]							Article no.
	ØD	ØDa	ØLkr.	n x Ød	e	n	C	
200	194	270	240	8 x Ø7	155	130	8	420-088-100096
250	244	320	290	12 x Ø7	155	130	8	420-088-100097
315	309	395	350	12 x Ø9	150	130	10	420-088-100098
400	400	480	445	16 x Ø9	150	130	10	420-082-000113
500	487	580	550	20 x Ø9	150	130	10	420-082-000000
630	630	722	690	24 x Ø11	150	130	15	
800	800	920	880	30 x Ø11	150	130	15	
1000	1000	1140	1090	36 x Ø14	150	130	15	

Dimensions and design are subject to change



Accessories for
HF - Axial fans
Type series HF A

Sleeve with flanges

For flexible connection with higher demands on tightness and at higher pressures

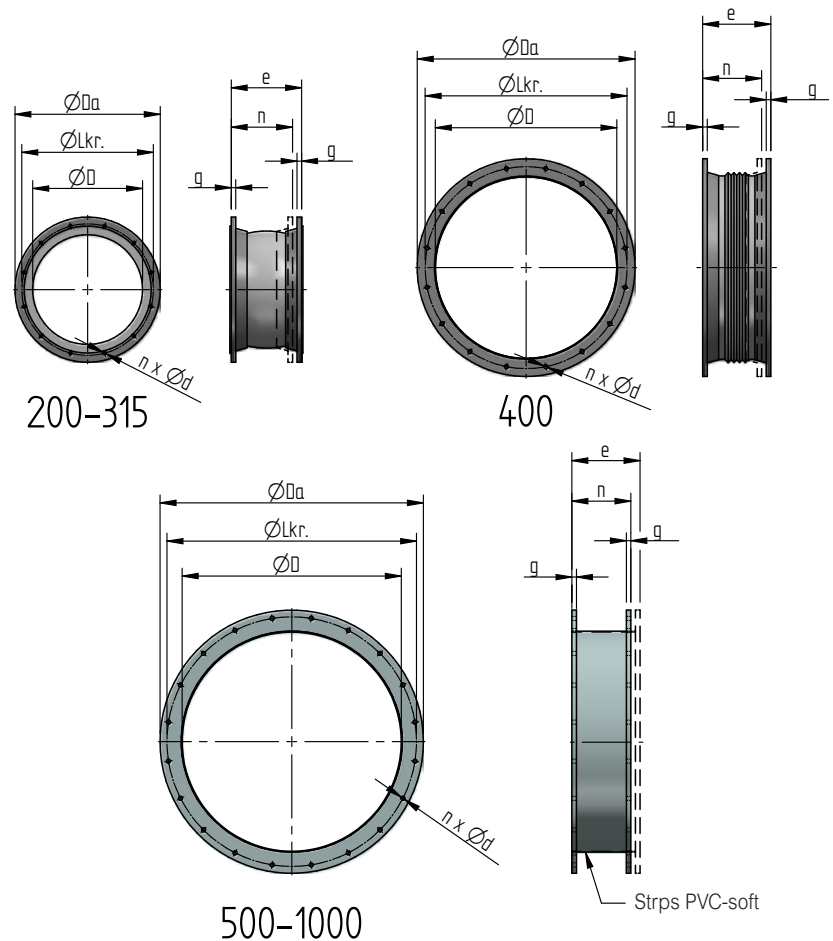

Size	Dimension [mm]							Article no.
	ØD	ØDa	ØLkr.	n x Ød	e	n	C	
200	194	270	240	8 x Ø7	155	130	8	420-083-000031
250	244	320	290	12 x Ø7	155	130	8	017-088-100119
315	309	395	350	12 x Ø9	150	130	10	420-083-100107
400	400	480	445	16 x Ø9	150	130	10	420-082-000113
500	487	580	550	20 x Ø9	150	130	10	420-083-000018
630	630	722	690	24 x Ø11	150	130	15	420-083-000019
800	800	920	880	30 x Ø11	150	130	15	420-083-000020
1000	1000	1140	1090	36 x Ø14	150	130	15	420-083-000021

Dimensions and design are subject to change

Accessories for
HF - Axial fans
Type series HF A



Shaft seal felt ring

Protects against leakage at the shaft passage



Size	Felt ring PPs	Felt ring PVC
Ø	Article no.	Article no.
200	441-040-A00200	441-040-A00201
250	441-040-A00250	441-040-A00251
315	441-040-A00316	441-040-A00315
400	441-040-A00400	441-040-A00401
500	441-040-A00500	
630	441-040-A00630	
800		
1000		

Protection grid

Protects against foreign bodies



Size	Inlet side	Outlet side
Ø	Article no.	Article no.
200	410-854-000000	410-854-000001
250	410-854-000010	410-854-000011
315	410-854-000020	410-854-000021
400	410-854-000030	410-854-000031
500	410-854-000040	410-854-000041
630	410-854-000050	410-854-000051
800	410-854-000060	410-854-000061
1000	410-854-000070	410-854-000071



Accessories for
HF - Axial fans
Type series HF A

Mounting feet

For easy horizontal mounting

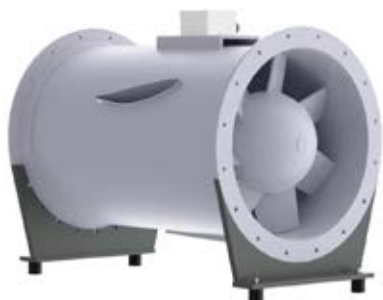
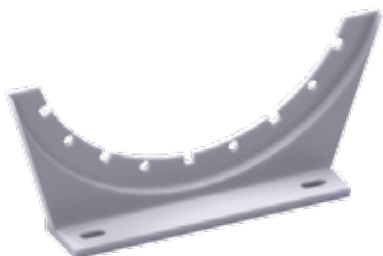

Size	PPs	PVC
Ø	Article no.	Article no.
200	441-010-000200	441-010-000200
250	441-010-000250	441-010-000251
315	441-010-000316	441-010-000315
400	441-010-000400	441-010-000401
500		441-010-000500
630	441-010-000631	
800		
1000	441-010-001001	441-010-001000

Wall bracket

For easy wall mounting



Accessories for
HF - Axial fans
Type series HF A ...-..° D
Repair switch | Connecting
diagram



Connecting diagram for standard three-phase motor

Motor cable		Switch Y (400 V)				Switch Δ (230 V)			
Cable no.	Winding	Pin	Motor cable no.	Mains	Pin	Motor cable no.	Mains		
1	U1	L1	-	(L1)	L1	-	(L1)		
2	V1	L2	-	(L2)	L2	-	(L2)		
3	W1	L3	-	(L3)	L3	-	(L3)		
4	U2	T1	1 (U1)	-	T1	1 (U1) + 6 (W2)			
5	V2	T2	2 (V1)	-	T2	2 (V1) + 4 (U2)			
6	W2	T3	3 (W1)	-	T3	3 (W1) + 5 (V2)			
7	PTC	Y-jumper {							
8	PTC	4 (U2)							
		5 (V2)							
		6 (W2)							

Connection diagram for motors with two speeds | separate winding

Motor cable		Connections at repair switch					
Cable no.	Winding	Switch pins			Motor cable no.		
1	U1	on-site connection 380 V 3-phase	← L1	T1 →	1 (U1)	} low speed	
2	V1		← L2	T2 →	2 (V1)		
3	W1		← L3	T3 →	3 (W1)		
4	U2		← 2L1	2T1 →	4 (U2)	} high speed	
5	V2		← 2L2	2T2 →	5 (V2)		
6	W2		← 2L3	2T3 →	6 (W2)		
7	PTC						
8	PTC						

Connection diagram for motors with two speeds | Dahlander pole changing motor

Motor cable		Connections at repair switch					
Cable no.	Winding	Switch pins			Motor cable no.		
1	U1	on-site connection 380 V 3-phase	← L1	T1 →	1 (U1)	} low speed	
2	V1		← L2	T2 →	2 (V1)		
3	W1		← L3	T3 →	3 (W1)		
4	U2		← 2L1	2T1 →	4 (U2)	} high speed U1 - V1 - W1 must be star connected	
5	V2		← 2L2	2T2 →	5 (V2)		
6	W2		← 2L3	2T3 →	6 (W2)		
7	PTC						
8	PTC						

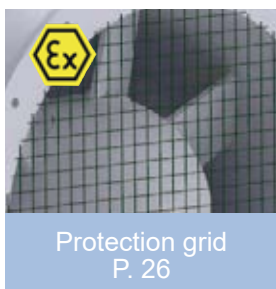

ATEX 2014/34/EU

HLU fans according to ATEX 2014/34/EU

The ATEX Directive 2014/34/EU regulates the requirements with regard to placing products on the market that are used in potentially explosive atmospheres. The term ATEX is derived from the French abbreviation "Atmosphère explosible" and is used as a synonym for the two directives of the

European Community in the area of explosion protection, ATEX Directive 2014/34/EU and ATEX Directive 1999/92/EG. The design of fans in the ATEX area is described in detail in the norms DIN EN 14986 and DIN EN ISO 80079.

Explosion protection is differentiated according the conveyed atmosphere (inside) and the surroundings of the installation site (outside).

HLU supplies fans for the ATEX Zones 2 and 1 for different zone combinations.

inside	outside
Zone 1	Zone 1
Zone 1	Zone 2
Zone 2	Zone 2
Zone 2	no Zone

HF -axial fan in ATEX version – for Zone 2 inside / no Zone outside:

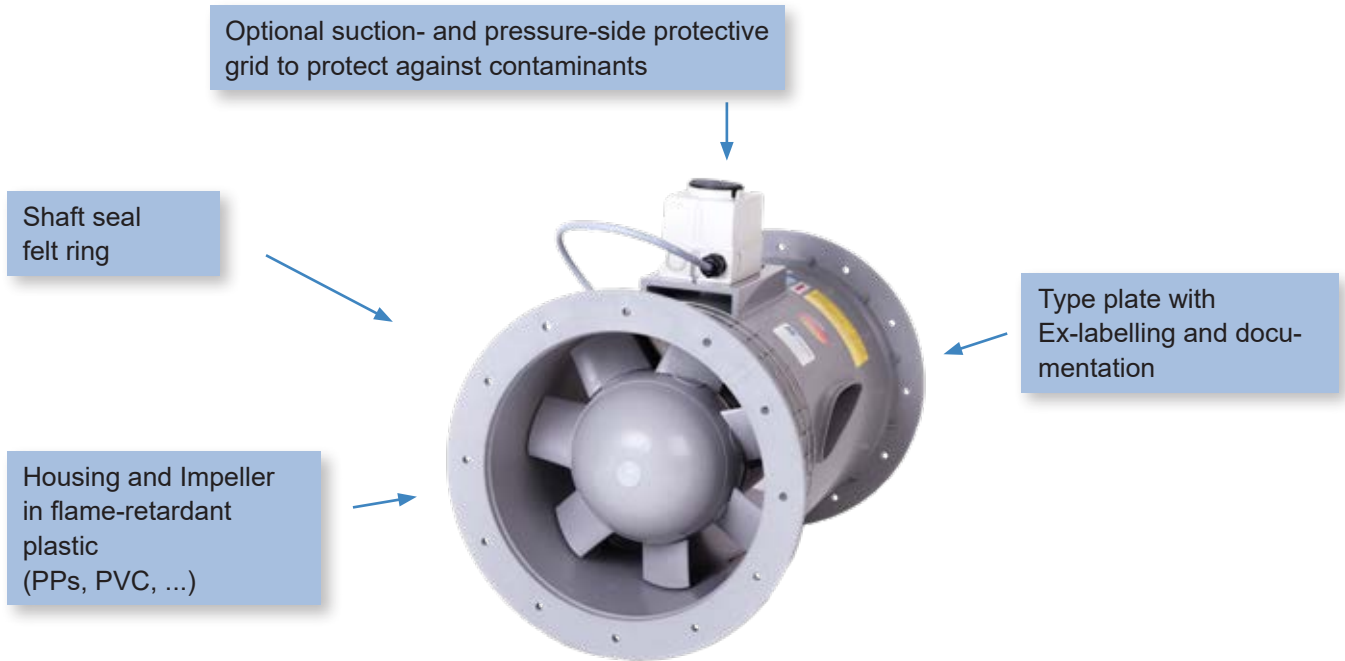

HF -axial fan in ATEX version – for Zone 2 inside / Zone 2 outside:

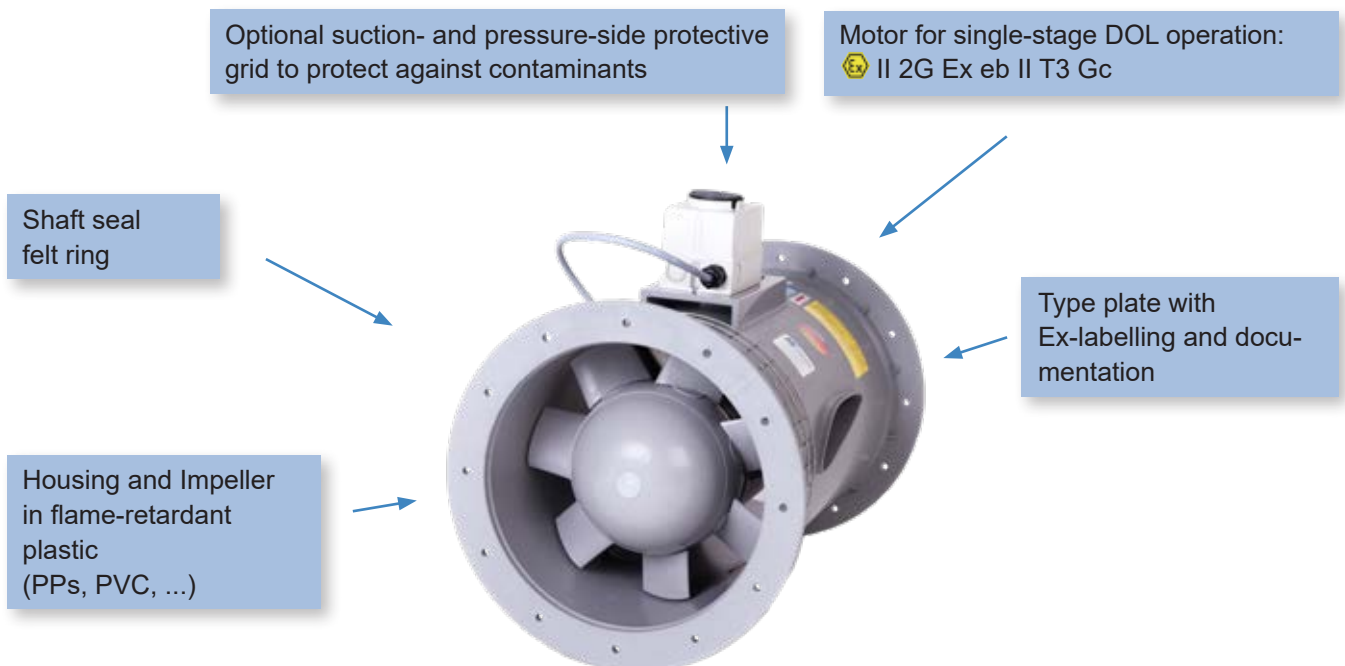

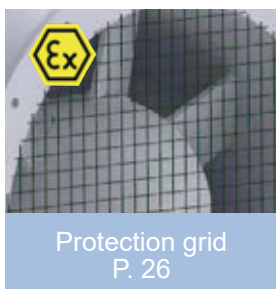

ATEX 2014/34/EU

You will see on the fan's type plate a permanent identification of the explosion protection. The following illustration explains the labelling of equipment for potentially explosive atmospheres:

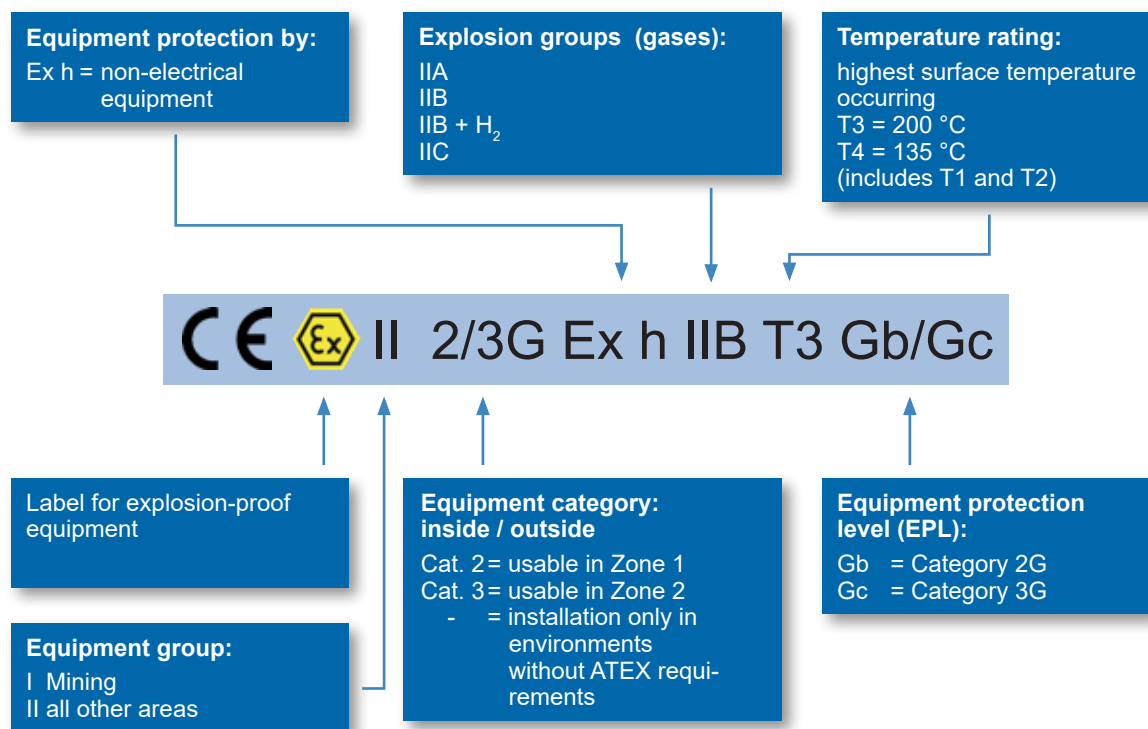

The operator of a facility is obligated to conduct a risk assessment. For questions regarding the Zone classification, you can contact various test centres such as for example safety engineers and special consultants. The following tables serve as reference:

An explosive gas atmosphere exists ...	ATEX Ex Zone	ATEX Device category	IEC EPL (International) (Equipment Protection Level)
for more than 30 min. per year, however, less than 50% of the operational period daily	Zone 1	Category 2G	Gb
for a max. of 30 min. in a year	Zone 2	Category 3G	Gc

www.plasticagroup.co.uk

Tel.: +44 (0) 1564 432 112 | info@plastica.tech

Plastica Technologies
Unit 2, Shaw Park Business Village,
Shaw Road,
Wolverhampton,
WV10 9LE,
UK